

S. D. LELAND.
TAP DRIVING HEAD.

No. 393,511.

Patented Nov. 27, 1888.

FIG. 4

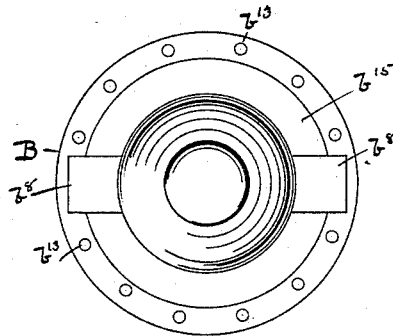
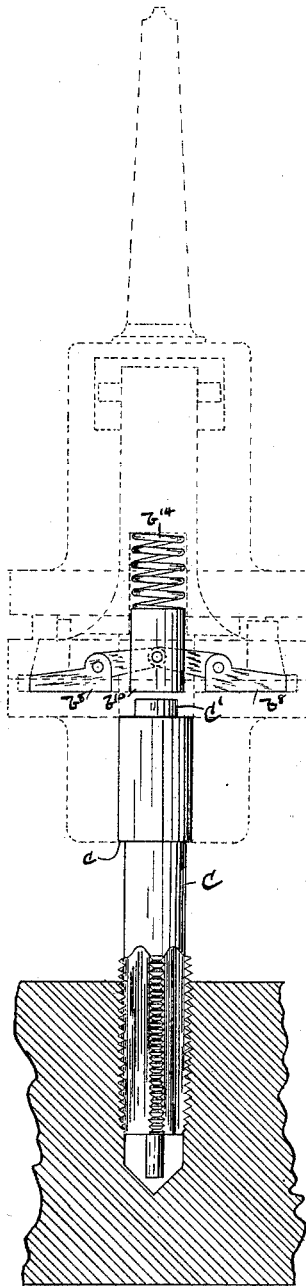

FIG. 6.

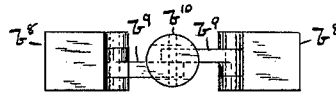
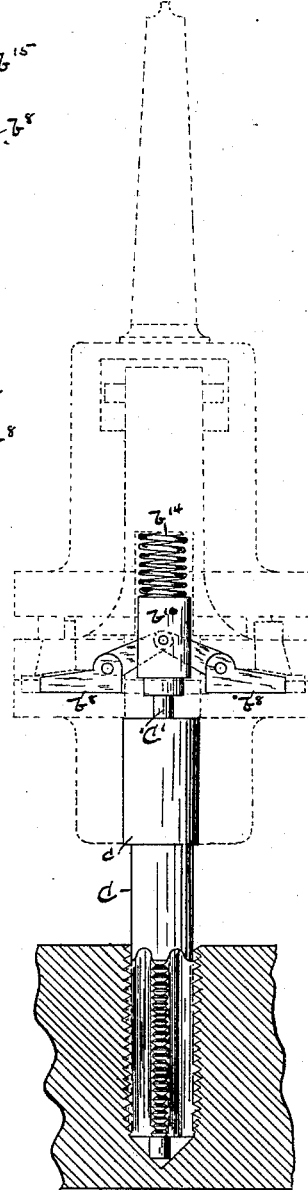

FIG. 7.



FIG. 8.

FIG. 5



Witnesses

H. Gardner,
J. I. LITTLE.

Inventor

S. D. Leland,
By James T. Chapman,
Attorneys.

UNITED STATES PATENT OFFICE.

SANFORD D. LELAND, OF HOLYOKE, MASSACHUSETTS, ASSIGNOR OF TWO-THIRDS TO GEORGE S. LEWIS AND FRANK E. FAY, BOTH OF SAME PLACE.

TAP-DRIVING HEAD.

SPECIFICATION forming part of Letters Patent No. 393,511, dated November 27, 1888.

Application filed March 19, 1888. Serial No. 267,618. (No model.)

To all whom it may concern:

Be it known that I, SANFORD D. LELAND, of Holyoke, in the county of Hampden and State of Massachusetts, have invented a new and useful Improvement in Self-Acting Tap-Heads, of which the following is a specification, reference being had to the accompanying drawings, forming part thereof.

The object of my invention is to provide a tap-head which will comprise within itself means for holding and revolving a screw-tap, and also for automatically stopping the revolution of the tap as the end of the latter approaches the bottom of the hole or orifice being tapped.

To this end my invention consists in a tap-head comprising within itself a friction-clutch, by means of which a revolving movement is transmitted from a revolving spindle to the tap, and automatic releasing devices for rendering said clutch inoperative to turn the tap as the end of the latter approaches the bottom of the hole within which it is operating.

My invention also comprises certain details of construction hereinafter fully described, and particularly pointed out in the claims.

Referring to the drawings, in which like letters designate like parts in the several figures, Figure 1 is a side elevation of the parts composing the tap-head as they appear previous to being assembled. Fig. 2 is a similar view of the same parts after being assembled. Fig. 3 is a vertical section of the parts as shown in Fig. 1. Fig. 4 shows the position of the releasing devices during the operation of the tap. Fig. 5 shows the position of the same parts after being tripped. Fig. 6 is a plan view of the tap-receiving hub. Fig. 7 is a similar view of the clutch holding and releasing wedges and their toggle-joint connection. Fig. 8 is a plan view of the upper end of the tap and an inverted plan of the bushing by which it is held in its hub.

The letter A designates the spindle, having the stem a , by means of which the tap-head is adapted to be secured to the spindle of the drill-press by which it is operated. I have deemed it to be unnecessary to show the press, as my invention relates wholly to the tap-

head, and because it will be understood by persons skilled in the art to which the invention relates that by inserting the stem of spindle A within the socket in the spindle of the ordinary drill-press the former can be revolved and also caused to advance and recede at will. At the end opposite to said stem a the spindle A terminates in the annular flange a' , from the face of which project two lugs, a^2 , preferably located at diametrically-opposite points on said flange, as shown. At its lower end spindle A is provided with a central bore to receive the stem b of hub B and at the inner end of said bore with an interior chamber, a^3 . An orifice, a^4 , extends laterally through the shell of the spindle into said chamber, and an interior lug, a^5 , extends upwardly from the bottom of said chamber, both for a purpose presently to be described.

The letter B designates the hub, having at its upper end stem b , adapted to fit loosely within the bore of spindle A and to project within chamber a^3 , said stem at its upper end being provided with a transverse orifice to receive a pin, b' , which pin, being of greater length than the diameter of the bore in the spindle, serves to retain the hub and spindle in operative engagement with each other, while permitting a limited movement longitudinally and a free rotary movement of the stem b within the spindle. At its lower end hub B is bored centrally to receive the tap, and at the inner end of the socket thus formed it is provided with an interior chamber, b^2 , of less diameter. In order to adapt the hub to receive and hold taps of different sizes, I prefer to provide the taps C with a bushing, c , the outer diameter of which is substantially that of the bore of the hub, so as to fit closely therein, while the inner diameter of each bushing will correspond with that of the particular tap with which it is designed to be used. I also prefer to make the upper end of the tap and an orifice in the head of the bushing of corresponding angular conformation, as shown in Fig. 8, whereby the former is prevented from revolving within the latter. To secure the bushings c within the hub, I provide the latter with an interior gib, b^3 , and with an adjusting-screw,

b^4 , bearing at its inner end against said gib, whereby the latter can be tightened against the bushing. A screw, b^5 , having its head located in a countersunk depression in the hub, is inserted at its inner end into said gib near the upper end of the latter, and a coil spring bearing at one end against the bottom of the depression in the hub and at the other end against the head of said screw flexibly retains the gib in its position. In the plane of the lower end of the chamber b^2 the hub B is provided with an opening, b^6 , extending transversely through it, and immediately in front of or below said opening with an annular flange, b^7 , having the same outer diameter as flange a^1 of the spindle. Seated within radial grooves in the upper or rear face of said flange b^7 are two blocks, b^8 , adapted to have a limited movement toward and away from each other. To the inner end of each of said blocks is pivoted a link, b^9 , the free ends of which links project within a transversely-slotted plug, b^{10} , where they are secured by a pivot, b^{11} , passing through said plug across the slot therein. Said links and plug thus form a toggle-joint, and said plug being fitted loosely within chamber b^2 , it follows that by moving the plug upwardly within said chamber the blocks b^8 will be drawn inwardly or toward each other, and by moving the plug downwardly said blocks will be moved outwardly or away from each other. Upon their upper surface the blocks b^8 are inclined downwardly toward their outer ends at a slight angle to their bottom surface, as shown.

The letter D designates a bearing-ring, the outer diameter of which corresponds to that of flanges a^1 and b^1 , the inner surface of which is beveled, as shown, and which is provided with recesses d in its lower surface to receive loosely the ends of the blocks b^8 .

The letter E designates a second bearing-ring whose outer diameter is slightly less than the inner diameter of ring D, and the outer surface of which is beveled to correspond with the inner surface of said ring D, whereby it is adapted to closely fit within the latter ring, as shown in Figs. 2, 4, and 5. The lower surface of said ring E is also preferably beveled to correspond with the inclined upper surfaces of blocks b^8 , as shown, and upon its upper surface said ring is provided with two lugs, e , located at diametrically-opposite points thereon. The bearing-ring D is secured to flange b^7 of the hub by screws or bolts passed therethrough and entering holes b^{12} in the flange. (See Fig. 6.) The rings D E thus form a friction-clutch by which, when the latter is closely held within the former, motion imparted to ring E will be transmitted to ring D and hub B. Said ring E, however, is capable of a slight vertical movement within ring D, and its position therein is governed by the position of blocks b^8 , which act as wedges against its lower surface. It will be obvious, therefore, that when said blocks occupy their outermost positions ring D and hub B will move in unison with ring E, and when said blocks occupy their in-

nermost positions said ring E can revolve freely without turning ring D or hub B.

When the parts are assembled, by inserting the stem of hub B within spindle A and inserting pin b' through orifice a^1 in the spindle and through the orifice in the upper end of stem b , and the spindle is lowered upon the hub, the lugs a^2 on the former are brought within the plane of revolution of lugs e on ring E, and by their contact therewith transmit the revolving movement of the spindle to said ring. When the lugs a^2 and e are in engagement with each other, pin b' lies above the plane of lug a^2 in chamber a^3 of the spindle and is free to revolve within said chamber, when, by releasing the friction-clutch D E, hub B becomes stationary, while the spindle and ring E continue their revolving movement. By raising the spindle, however, until the pin b' is brought into contact with the bottom of chamber a^3 and lugs a^2 are elevated above the plane of lugs e the lug a^2 is brought within the plane of said pin, and by its contact therewith causes hub B to revolve with the spindle in withdrawing the tap from its orifice after the completion of its work. The devices which govern the position of plug b^{10} and blocks b^8 are a coil-spring, b^{11} , located in chamber b^2 above the plug and normally retaining it in its lowest position, and a rod, C', extending centrally through the tap and projecting beyond the ends thereof, a flange at the upper end of said rod retaining it within the tap, and, until the latter approaches the bottom of the orifice within which it is operating, occupies the position shown in Fig. 4. By the continued movement of the tap the lower end of said rod is brought into contact with the bottom of the orifice and it is gradually elevated within the tap until its upper end abuts against the bottom of plug b^{10} , and by elevating the latter against the stress of spring b^{11} and moving blocks b^8 inwardly it releases the clutch D E, and thereby stops the movement of the tap.

I have shown the hub as being provided with a shoulder, b^{15} , immediately above flange b^7 , said shoulder having its upper surface beveled to correspond with the bevel of the lower surface of ring E, whereby said shoulder is adapted to support said ring when the blocks b^8 are drawn inwardly; but it is obvious that other means for supporting said ring can be employed, and I do not wish to limit myself to the use of such shoulder.

The operation of the tap-head thus constructed will be obvious from the above description. The stem a of spindle A being secured within the spindle of a drill-press or within the head-stock of a lathe, and the tap C, corresponding in size to the particular orifice to be tapped, being inserted in hub B by means of its bushing c and applied to the orifice, the drill-press spindle or lathe head-stock is set in operation in the usual manner. The movement of spindle A is transmitted through

lugs a^2 e and rings D E to hub B and the tap, the blocks b^8 and rod C being in the position shown in Figs. 2 and 4. When the tap reaches the bottom of the orifice, the rod C moves the blocks b^8 to the position shown in Fig. 5, as previously described, and the tap ceases to revolve. The movement of the drill-press spindle or lathe head-stock is then reversed in the usual manner, and, the reverse movement of spindle A being transmitted to hub B through pin b^7 and lug a^5 , the tap is drawn from the orifice and the operation is completed.

It will be observed that the tap-head herein described is wholly automatic, so far as stopping the movement of the tap is concerned, thereby avoiding all possibility of injury to the tap through the carelessness of the operator. It will be observed, furthermore, that by varying the length of rod C the movement of the tap can be stopped at any desired distance above the bottom of the orifice in which it operates when it is not desired to tap said orifice entirely to the bottom thereof. The tap-head herein described is also adapted to tap holes which extend entirely through the material in which they are located in the usual manner, and its automatic feature can be utilized in such case by arranging a suitable stop upon the rear side of the stock and opposite the orifice extending therethrough, with which the end of rod C can contact as the tap approaches the rear end of said orifice.

I do not wish to limit myself to the construction herein described in all of its various details, as modifications therein can be made without departing from the spirit of my invention.

Having thus fully described my invention, what I claim, and desire to secure by Letters Patent, is—

1. The self acting tap-head herein described, consisting of a hub having a socket to receive the tap, a spindle operatively connected with said hub by means of a clutch, a tap seated in the socket of said hub, and a clutch-releasing device located within said tap and projecting beyond the end thereof, substantially as and for the purpose set forth.

2. The tap-head herein described, consisting of a hub having means for securing the end of a tap therein and having connected therewith a friction-clutch, and sliding wedge-shaped blocks connected together by a toggle-joint for locking and releasing the two members of said clutch, in combination with a spindle having projecting lugs for engaging lugs upon one of the members of said clutch, and a tap having centrally disposed therein a rod or similar device for operating said toggle-joint to release said clutch, substantially as described.

3. The tap-head herein described, consist-

ing of spindle A, having a central bore and projecting lugs, as shown, hub B, having stem b , adapted to fit loosely in the bore of said spindle, and having at its opposite end a socket to receive the tap, said socket terminating in the chamber b^2 , blocks b^8 , located in a transverse opening in said hub and connected by links b^9 with plug b^{10} , located in said chamber b^2 , ring D, secured to said hub and having its inner surface beveled, as shown, ring E, located within said ring D, said ring E having its outer surface beveled, as shown, and having projecting lugs e , spring b^{14} , located in chamber b^2 , above said plug b^{10} , and tap C, having rod C extending longitudinally therethrough, combined and operating substantially as set forth.

4. In a tap-head, the combination, with spindle A, having a central bore terminating in chamber a^3 , and having lug a^5 , projecting upwardly within said chamber, and orifice a^4 , leading into said chamber, of hub B, provided with the tap receiving socket, friction-clutch, and clutch-releasing devices, substantially as described, said hub having stem b , adapted to be inserted within the bore of spindle A and to project within said chamber a^3 , said stem being provided at its upper end with an orifice extending transversely therethrough, and pin b^7 , adapted to be inserted through orifice a^4 of said spindle and seated within the orifice in said stem b , substantially as and for the purpose described.

5. In a tap-head, the combination, with hub B, having a tap-receiving socket in its lower end, of gib b^3 , located within a recess in the wall of said socket, screw b^5 , secured at its inner end to said gib and having its head located within a countersunk depression in said hub, a spring located between the head of said screw and the bottom of said depression, and adjusting-screw b^4 , bearing at its inner end against said gib, substantially as and for the purpose described.

6. In a tap-head, the combination, with spindle A, having lugs a^2 , of hub B, having flange b^7 , beveled shoulder b^5 , and transverse opening b^6 , wedge-shaped blocks b^8 , sliding within grooves in said flange and shoulder, said blocks being connected together by a toggle-joint, ring E, having its outer and lower surfaces beveled, as shown, and having lugs e projecting from its upper surface, and ring D, having its inner surface beveled to correspond with the bevel of the outer surface of said ring E, substantially as and for the purpose described.

SANFORD D. LELAND.

Witnesses:

W. H. CHAPMAN,
T. M. BROWN.